

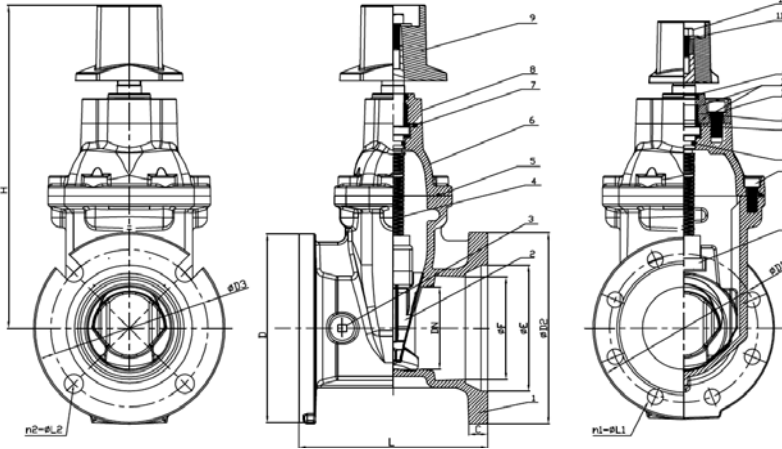

MATERIAL SPECIFICATION

PART NO.	Description	Material Specification	Options
1	Valve Body	Ductile Iron ASTM A536,65-45-12	
2	Resilient Wedge Disc	Ductile Iron ASTM A536,65-45-12+EPDM	
3	Plug	ASTM B62 C83600	
4	Stem	Stainless steel 316	Stainless steel AISI 304/431, Bronze ASTM B584
5	Bonnet Gasket	EPDM ASTM D2000	NBR ASTM D2000
6	Bonnet	Ductile Iron ASTM A536,65-45-12	
7	O-Ring	NBR ASTM D2000	EPDM ASTM D2000
8	Gland Flange	Ductile Iron ASTM A536,65-45-12	
9	Square Operating Nut	Ductile Iron ASTM A536,65-45-12	
10	Bolt	Stainless steel 316	Stainless steel 304
11	Flat Washer	Stainless steel 316	Stainless steel 304
12	Ring Wiper	EPDM ASTM D2000	NBR ASTM D2000
13	O-Ring	NBR ASTM D2000	EPDM ASTM D2000
14	Bolt	Stainless steel 316	Stainless steel 304
15	Axis Guide	Brass ASTM B-283 C37700	
16	Washer	Brass ASTM B-283 C37700	
17	O-Ring	NBR ASTM D2000	EPDM ASTM D2000
18	Bolt	Stainless steel 316	Stainless steel 304
19	Wedge Nut	Brass ASTM B-283 C37700	Bronze ASTM B-584 Alloy C89833

Note: For special material request other than standard specification, please indicate clearly on the inquiry or order list.



- Connection Ends: Flange to ASME B16.1 CL 125
Mechanical Joint to ANSI/AWWA C153/A21.53
- Working Pressure: 300PSI
200PSI and 250PSI available upon request
- Temperature Range: 0°-80°C
- Coating: Fusion Bonded Epoxy Coating in accordance with ANSI/AWWA C550.

DN	Dimensions(Inch)										
	L	H	D	D1	D2	D3	E	F	C	n1-ΦL1	n2-ΦL2
2"	7.0	10.94	5.98	4.74	5.98	4.74	3.50	2.61	0.63	4-Φ0.75	2-Φ0.75
3"	8.0	12.64	7.52	6.00	7.68	6.18	4.94	4.06	0.75	4-Φ0.75	4-Φ0.75
4"	9.0	14.76	9.02	7.50	9.13	7.50	6.02	4.90	0.75	8-Φ0.75	4-Φ0.88
6"	10.5	17.91	10.98	9.50	11.10	9.50	8.12	7.00	0.75	8-Φ0.88	6-Φ0.88
8"	11.5	22.24	13.50	11.75	13.39	11.73	10.27	9.15	0.87	8-Φ0.88	6-Φ0.88
10"	13.0	25.04	15.98	14.25	15.63	14.00	12.34	11.20	0.94	12-Φ1	8-Φ0.88
12"	14.0	28.78	19.02	17.00	17.87	16.25	14.44	13.30	1.00	12-Φ1	8-Φ0.88



DRAWN BY: Cindy Zhang	DRAWING # JMZ05XC	AWWA C515 Flanged x Mechanical Joint NRS Gate Valve	
		Series NO.:JMZ05XC	
CHECKED BY: Cherry Chen		 KINGER INDUSTRY INC.	REV.00.
APPROVED BY: Meng Xiang	ISSUE DATE 160726-02		