

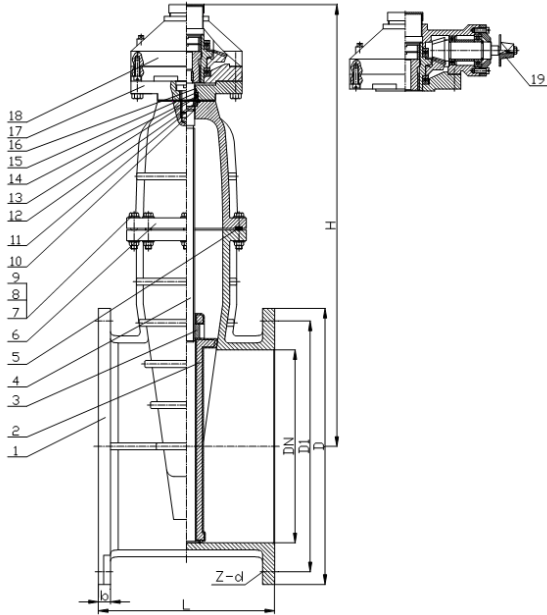

- Connection Ends: Flange to ASME B16.1 CL125
- Working Pressure: 250PSI
- Temperature Range: 0°-80°C
- Coating: Fusion Bonded Epoxy Coating in accordance with ANSI/AWWA C550. All JHZ series can be equipped with Gearbox.



MATERIAL SPECIFICATION

PART NO.	Description	Material	Material standard
1	Body	Ductile Iron	ASTM A536
2	Wedge	Ductile Iron /EPDM	ASTM A536/D2000
3	Stem Nut	Brass	ASTM B16
4	Stem	Stainless steel	SS420
5	Gasket	EPDM	ASTM D2000
6	Bonnet	Ductile Iron	ASTM A536
7	Bonnet Bolt	Stainless steel	A3
8	Nut	Stainless steel	A3
9	Washer	Stainless steel	A3
10	O-Ring	EPDM	ASTM D2000
11	Minipad	TFL	
12	Locating Ring	Brass	ASTM B16
13	Seal Ring	Brass	ASTM B16
14	O-Ring	EPDM	ASTM D2000
15	O-Ring	EPDM	ASTM D2000
16	Dust Ring	EPDM	ASTM D2000
17	Gland	Ductile Iron	ASTM A536
18	Wheel Gear Box		
19	Cap	Ductile Iron	ASTM A536

Note: For special material request other than standard specification, please indicate clearly on the inquiry or order list.



DN	Dimensions (Inch)					
	D	D1	H	L	b	Z-d
4"	9.02	7.5	19.96	9.02	0.94	8-ø0.75
5"	10	8.5	22.13	10	0.94	8-ø0.87
6"	10.98	9.51	23.62	10.51	1.00	8-ø0.87
8"	13.5	11.75	27.05	11.5	1.14	8-ø0.87
10"	15.98	14.25	30.43	12.99	1.20	12-ø1
12"	19.02	17.01	33.90	14.02	1.26	12-ø1
14"	20.98	18.74	36.73	15	1.38	12-ø1.14
16"	23.5	21.24	39.76	15.98	1.46	16-ø1.14
18"	25	22.75	42.87	17.01	1.56	16-ø1.26
20"	27.52	25	45.98	17.99	1.69	20-ø1.26
24"	32.01	29.51	52.28	20	1.89	20-ø1.38
30"	38.74	36	60.24	24.02	2.13	28-ø1.38
36"	45.98	42.76	65.94	27.99	2.38	32-ø1.61

DRAWN BY:
Cindy Zhang

DRAWING #
JHZ45XC-G

AWWA C509 Flanged Resilient NRS Gate Valve With Capnut & Gearbox
Series NO.: JHZ45XC-G

CHECKED BY:
Cherry Chen

APPROVED BY:
Meng Xiang

ISSUE DATE
161116-01



REV.00.