

Item No.	NPS	Dimensions(Inch)											
		A	B	C	D	E	F	G	H	J	K	L	P
KPL175-GS02	2"	7.00	0.75	3.39	5.85	1.58	6.50	4.75	0.75	2	5/8-11UNC	2	8.0
KPL175-GS025	2.5"	7.50	0.75	3.39	5.85	1.58	7.28	5.50	0.75	2	5/8-11UNC	2	8.0
KPL175-GS03	3"	8.00	0.75	3.82	6.28	1.58	7.87	6.00	0.75	4	N/A	N/A	8.0
KPL175-GS04	4"	9.00	0.94	4.90	7.40	1.58	9.00	7.50	0.75	6	5/8-11UNC	2	8.0
KPL175-GS06	6"	10.50	1.00	6.30	9.25	1.58	11.22	9.50	0.88	4	3/4-10UNC	4	12.0
KPL175-GS08	8"	11.50	1.13	7.32	10.57	1.90	13.50	11.75	0.88	4	3/4-10UNC	4	18.0
KPL175-GS10	10"	13.00	1.19	9.45	12.93	1.90	15.98	14.25	1.00	4	7/8-9UNC	8	20.0
KPL175-GS12	12"	14.00	1.25	10.55	14.17	1.90	19.00	17.00	1.00	4	7/8-9UNC	8	24.0

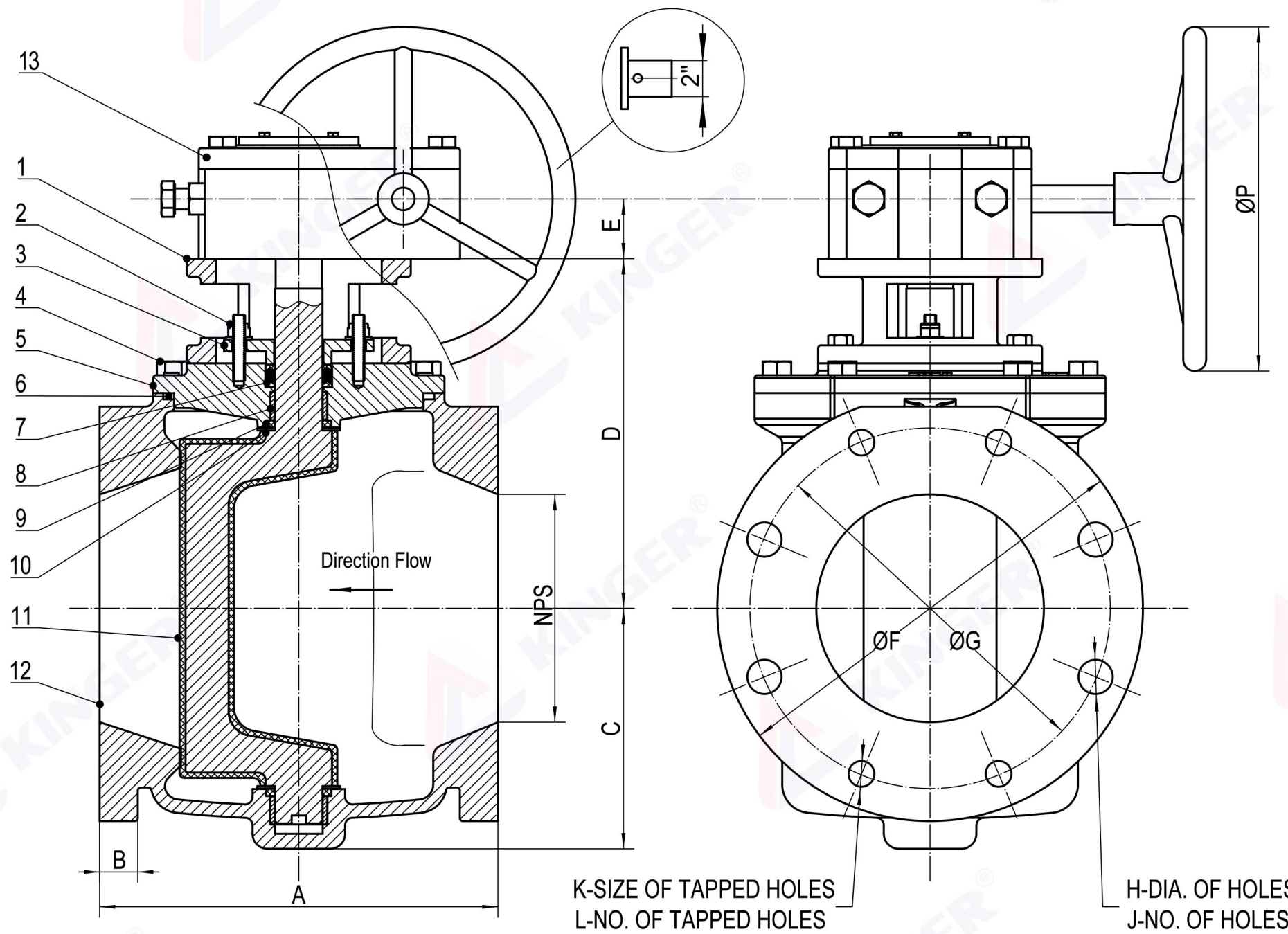

Specification		
Cold Working Pressure (CWP)		175
Test Pressure	Shell Test(Hyd.)	265
	Seal Test(Hyd.)	175
	Reverse Pressure Test(Hyd.)	100
Working Temperature		32°F -176°F
Medium		Water



NOTES:

1. ALL DIMENSIONS ARE IN INCHES ;
2. DESIGN STANDARD PER AWWA C517 ;
3. FLANGE STANDARD PER ASME B16.1 CLASS125 ;

Part No.	DESCRIPTION	MATERIAL
1	ADAPTER	ASTM A536 65-45-12
2	GLAND FASTENER	SS316
3	GLAND	ASTM A536 65-45-12
4	BOLTS	SS316
5	BONNET	ASTM A536 65-45-12
6	O-RING	NBR
7	V-PACKING	NBR
8	SLEEVE BEARING	SS316
9	GRIT SEAL	NBR
10	THRUST WASHER	PTFE
11	PLUG	ASTM A536 65-45-12+NBR
12	BODY	ASTM A536 65-45-12+95%Ni
13	Worm Gear	Assembly

DESCRIPTION	Proj.	KPL175-GS	
AWWA C517 Flanged Eccentric Plug Valve	DWG#	KPL-002	
	REV.	0	
	DWN	APPR.	DATE
	CINDY	KUHN	9/23/2021