

AWWA C515 Flanged Resilient OS&Y Gate Valve 300PSI (JKDZ41-300A)

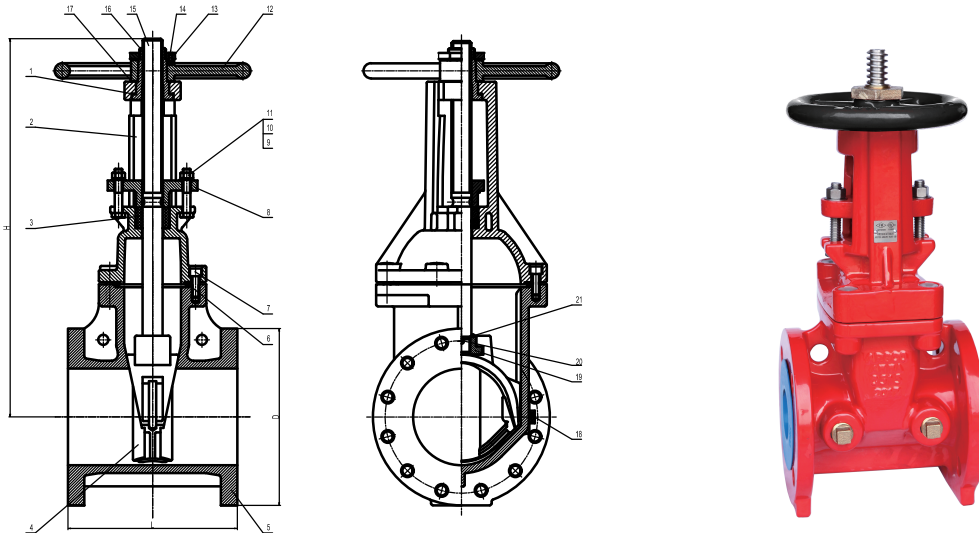
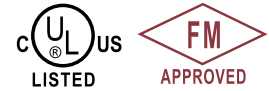

MATERIAL SPECIFICATION

Part NO.	Description	Material Specification	Options
1	Washer	Bronze ASTM B148 C95400	Stainless Steel S.S.304
2	Bonnet	Ductile Iron ASTM A536	
3	Stem Packing	Graphite	
4	Disc & Encapsulate	Ductile Iron ASTM A536 + EPDM ASTM D2000	
5	Body	Ductile Iron ASTM A536	
6	Bonnet O Ring	EPDM ASTM D2000	
7	Bonnet Bolt	Carbon Steel Black	Galvanized Steel/Stainless Steel S.S.304
8	Gland	Ductile Iron ASTM A536	
9	Gland Nut	Stainless Steel S.S.304	Galvanized Steel
10	Flat Washer	Stainless Steel S.S.304	Galvanized Steel
11	Gland Bolt	Stainless Steel S.S.304	Galvanized Steel
12	Handwheel	Ductile Iron ASTM A536	
13	Lock Nut	Bronze ASTM B148 C95400	
14	Locating Screw	Stainless Steel S.S.304	Galvanized Steel
15	Stem	Stainless Steel S.S.304	Stainless Steel S.S.316/431
16	Cap Nut	Bronze ASTM B148 C95400	
17	Washers	Bronze ASTM B148 C95400	Galvanized Steel/Stainless Steel S.S.304
18	Plug	Bronze ASTM B148 C95400	
19	Stem Nut	Stainless steel S.S.304	Stainless Steel CF8/CF8M
20	Pin	Stainless Steel S.S.304	
21	O Ring	EPDM ASTM D2000	

Note: For special material request other than standard specification, please indicate clearly on the inquiry or order list.

Item No.	SIZE	Dimensions(IN)						
		Dn	L	D	C	n-d	H	Diameter of Handwheel A
JKDZ41-300FLG25	2.5"	2.50	7.48	7.09	5.51	4-Φ0.75	14.57	7.24
JKDZ41-300FLG03	3"	3.00	7.99	7.48	5.98	4-Φ0.75	16.54	10
JKDZ41-300FLG04	4"	4.00	9.02	9.05	7.52	8-Φ0.75	17.60	10
JKDZ41-300FLG05	5"	5.00	10.00	10.04	8.50	8-Φ0.87	21.54	12.2
JKDZ41-300FLG06	6"	6.00	10.51	11.02	9.49	8-Φ0.87	23.90	12.2
JKDZ41-300FLG08	8"	8.00	11.50	13.58	11.77	8-Φ0.87	29.69	14
JKDZ41-300FLG10	10"	10.00	12.99	15.95	14.25	12-Φ1.00	35.04	17.5
JKDZ41-300FLG12	12"	12.00	14.02	19.09	17.01	12-Φ1.00	40.59	17.5

- Connection Ends: Flange to ASME B16.1 CL 125/150
- Working Pressure: 300PSI
- Temperature Range: 32 -176
- Coating: Fusion Bonded Epoxy Coating in accordance with ANSI/AWWA C550