

Flanged Resilient Swing Check Valve Weight & Lever 200PSI/250PSI/300PSI (JHH44X W)

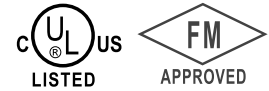

MATERIAL SPECIFICATION

PART NO.	Description	Material Specification	Options
1	Valve Body	Ductile Iron ASTM A536	
2	Body Seat Ring	Bronze ASTM B62	
3	Disk Seat Ring	Bronze ASTM B62	
4	Disc	Ductile Iron ASTM A536	
5	Washer	Stainless Steel SS304	
6	Nut	Stainless Steel SS304	
7	Cotter PIN	Stainless Steel SS304	
8	Arm	Ductile Iron ASTM A536	
9	Hing PIN	Stainless Steel SS420	
10	Plug	Carbon Steel	
11	Gasket	TFL	
12	Gasket	NBR ASTM D2000	
13	Bonnet	Ductile Iron ASTM A536	
14	Bolt	Carbon Steel A3	
15	Nut	Carbon Steel A3	
16	Gland	Ductile Iron ASTM A536	
17	Hinge	Ductile Iron ASTM A536	
18	Hammer	Ductile Iron ASTM A536	

- Connection Ends: Flange to ASME B16.1 CL 125
- Working Pressure: 200PSI/250PSI/300PSI
- Temperature Range: 32°H-176°H
- Coating: Fusion Bonded Epoxy Coating in accordance with ANSI/AWWA C550

Note:For special material request other than standard specification,please indicate clearly on the inquiry or order list.

Item No.	DN	Dimensions(Inch)					
		D	D1	L	b	Z-d	H
JHH44XW15FLG	1.5"	5.00	3.88	6.50	0.59	4- -0.63	4.72
JHH44XW02FLG	2"	5.98	4.74	7.99	0.63	4- -0.75	5.39
JHH44XW25FLG	2.5"	7.01	5.49	8.50	0.69	4- -0.75	5.63
JHH44XW03FLG	3"	7.52	6.00	9.49	0.75	4- -0.75	6.06
JHH44XW04FLG	4"	9.02	7.50	11.50	0.94	8- -0.75	6.73
JHH44XW05FLG	5"	10.00	8.50	12.99	0.94	8- -0.87	8.03
JHH44XW06FLG	6"	10.98	9.51	14.02	1.00	8- -0.87	8.62
JHH44XW08FLG	8"	13.50	11.75	19.49	1.14	8- -0.87	10.16
JHH44XW10FLG	10"	15.98	14.25	24.49	1.20	12- -1.00	11.42
JHH44XW12FLG	12"	19.02	17.01	27.48	1.26	12- -1.00	12.80
JHH44XW14FLG	14"	20.98	18.74	30.98	1.38	12- -1.14	14.21
JHH44XW16FLG	16"	23.50	21.26	35.98	1.46	16- -1.14	15.28
JHH44XW18FLG	18"	25.00	22.75	36.50	1.56	16- -1.26	17.72
JHH44XW20FLG	20"	27.52	25.00	37.64	1.69	20- -1.26	20.39
JHH44XW24FLG	24"	32.01	29.51	44.02	1.89	20- -1.38	24.41
JHH44XW30FLG	30"	38.74	36.00	55.98	2.13	28- -1.38	30.04