

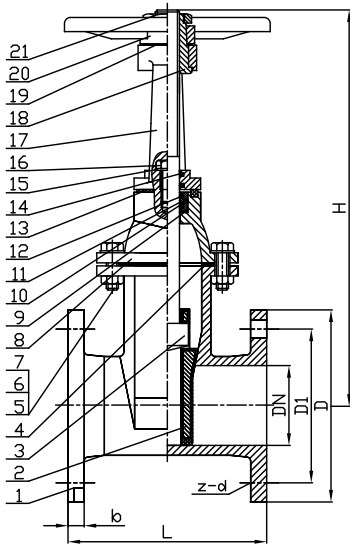

## AWWA C509 Flanged Resilient OS&Y Gate Valve (JHZ41XQ)



### MATERIAL SPECIFICATION

Part No.	Description	Material	Material Standard
1	BODY	DUCTILE IRON	ASTM A536
2	WEDGE, Rubber Encapsulated	DUCTILE IRON/EPDM	ASTM A536/ASTM D2000
3	STEM	STAINLESS STEEL	SS304
4	BONNET GASKET	EPDM	ASTM D2000
5	BONNET BOLT	STAINLESS STEEL	SS304
6	BONNET NUT	STAINLESS STEEL	SS304
7	BONNET WASHER	STAINLESS STEEL	SS304
8	BONNET	DUCTILE IRON	ASTM A536
9	WASHER	TFL	
10	O-RING	EDPM	ASTM D2000
11	SEAL RING	BRASS	ASTM B16
12	STEM O-RING	EDPM	ASTM D2000
13	SUTFFING BOX SEAL	TFL	ASTM A536
14	DUST RING	EPDM	ASTM D2000
15	WASHER	STAINLESS STEEL	SS304
16	BOLT	STAINLESS STEEL	SS304
17	YOKE	DUCTILE IRON	ASTM A536
18	STEM NUT	BRASS	ASTM B16
19	WASHER	TFL	
20	HANDWHEEL	DUCTILE IRON	ASTM A536
21	LOCKING NUT	BRASS	ASTM B16

Note: For special material request other than standard specification, please indicate clearly on the inquiry or order list.

DN	Dimensions(Inch)					
	D	D1	b	z-d	L	H
1.5"	5.00	3.88	0.59	4-Φ0.630	6.50	11.02
2"	5.98	4.74	0.63	4-Φ0.748	7.01	11.61
2.5"	7.01	5.49	0.69	4-Φ0.748	7.48	12.99
3"	7.52	6.00	0.75	4-Φ0.748	7.99	14.37
4"	9.02	7.50	0.94	8-Φ0.748	9.02	16.73
5"	10.00	8.50	0.94	8-Φ0.866	10.00	19.88
6"	10.98	9.51	1.00	8-Φ0.866	10.51	22.64
8"	13.50	11.75	1.14	8-Φ0.866	11.50	28.54
10"	15.98	14.25	1.20	12-Φ0.984	12.99	34.06
12"	19.02	17.01	1.26	12-Φ0.984	14.02	39.17
14"	20.98	18.74	1.38	12-Φ1.142	15.00	44.29
16"	23.50	21.24	1.44	16-Φ1.142	15.98	49.41
18"	25.00	22.75	1.56	16-Φ1.260	17.01	54.53
20"	27.52	25.00	1.69	20-Φ1.260	17.99	59.65
24"	32.01	29.51	1.89	20-Φ1.378	20.00	70.08

- Connection Ends: Flange to ASME B16.1 CL 125
- Working Pressure: 250PSI
- Temperature Range: 0°C - 80°C
- Coating: Fusion Bonded Epoxy Coating in accordance with ANSI/AWWA C550

