

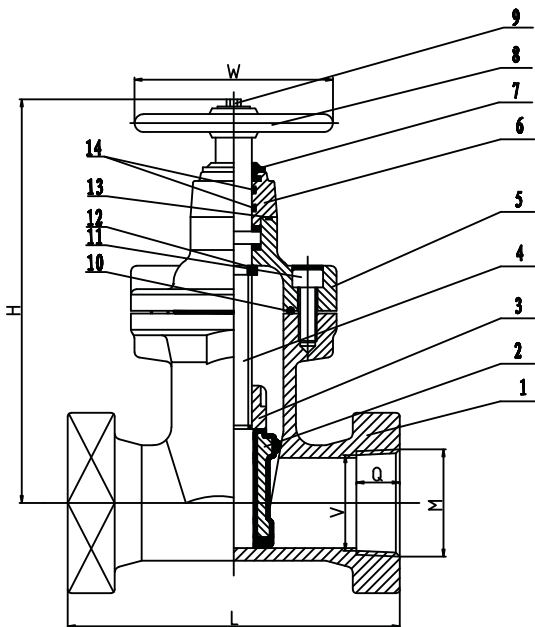

## AWWA C515 IPS Thread End Resilient NRS Gate Valve (JQZ002)



### MATERIAL SPECIFICATION

PART NO.	Description	Material Specification	Options
1	Body	Ductile Iron ASTM A536,65-45-12	
2	Wedge	Ductile Iron ASTM A536,65-45-12+EPDM	
3	Stem Nut	Brass ASTM B-283 C37700	Bronze ASTM B-584 Alloy C89833
4	Stem	Stainless steel 420	Stainless Steel AISI 304/431, Bronze ASTM B584
5	Bonnet	Ductile Iron ASTM A536,65-45-12	
6	Gland	Ductile Iron ASTM A536,65-45-12	
7	Dust Cap	NBR ASTM D2000	EPDM ASTM D2000
8	Handwheel	Ductile Iron ASTM A536,65-45-12	Pressed Steel
9	Bolts	Carbon Steel	Stainless Steel AISI 304
10	Gasket	EPDM ASTM D2000	NBR ASTM D2000
11	Bolts	Carbon Steel	Stainless Steel AISI 304
12	O-Ring	NBR ASTM D2000	EPDM ASTM D2000
13	O-Ring	NBR ASTM D2000	EPDM ASTM D2000
14	O-Ring	NBR ASTM D2000	EPDM ASTM D2000

Note: For special material request other than standard specification, please indicate clearly on the inquiry or order list.

SIZE	Dimensions(Inch)					
	L	M	H	Q	W	V
2"	7.24	2.37	9.84	0.79	7.09	1.97
2.5"	7.48	2.87	10.39	1.14	7.09	2.56
3"	7.99	3.50	11.22	1.22	7.87	3.15
4"	9.02	4.50	14.17	1.30	9.84	3.94
6"	10.51	6.45	17.28	1.52	9.84	5.91

- Connection Ends: Thread ANSI B1.20.1-NPT
- Working Pressure: 250PSI
- Temperature Range: 0°C- 80°C
- Coating: Fusion Bonded Epoxy Coating in accordance with ANSI/AWWA C550