

# Wall Indicator Post (JMDWP)

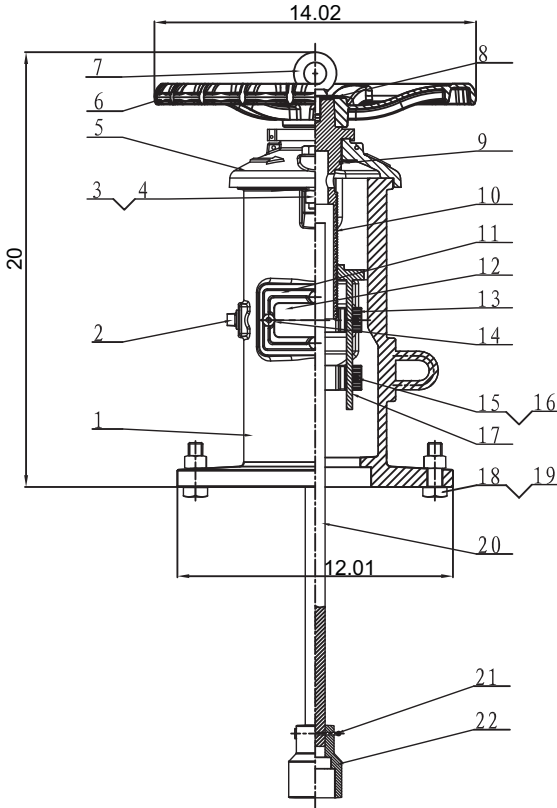

- Coating: Fusion Bonded Epoxy Coating Complies with ANSI/AWWA C550.
- Applications: Potable Water, Water Distribution Service & Feed lines, Sewage Disposal, Irrigation and Fire Protection Pipe System etc.



## MATERIAL SPECIFICATION

PART NO.	Description	Material Specification	Options
1	Body	Ductile Iron ASTM A126 Class B	
2	Plug	Malleable Iron Galvanized	
3	Square Nut	Carbon Steel Zinc Plated	Stainless steel 304/316
4	Hex Bolt	Carbon Steel Zinc Plated	Stainless steel 304/316
5	Cover	Cast Iron ASTM A126 Class B	
6	Handwheel	Ductile Iron ASTM A536 , 65-45-12	
7	Eye Bolt	Carbon Steel ASTM A307B	
8	Washer	Carbon Steel ASTM A307B	
9	Snap Ring	Stainless steel AISI1066	
10	Operating Nut	Stainless steel 304	Stainless steel 316
11	Gasket	PTFE	
12	Window Class	Plexiglass	
13	Instructs The Plane	Cast Aluminium	
14	Hex Bolt	Carbon Steel Zinc Plated	Stainless steel 304/316
15	Hex Bolt	Carbon Steel Zinc Plated	Stainless steel 304/316
16	Hex Nut	Carbon Steel Zinc Plated	Stainless steel 304/316
17	Target Carrier Nut	Stainless steel 304	Stainless steel 316
18	Hex Nut	Carbon Steel Zinc Plated	Stainless steel 304/316
19	Hex Bolt	Carbon Steel Zinc Plated	Stainless steel 304/316
20	Stem 1" Square	Carbon Steel AISI 1045	
21	Cotter Pin	Stainless steel 304	Stainless steel 316
22	Socket	Ductile Iron ASTM A536 , 65-45-12	

Note: For special material request other than standard specification, please indicate clearly on the inquiry or order list