

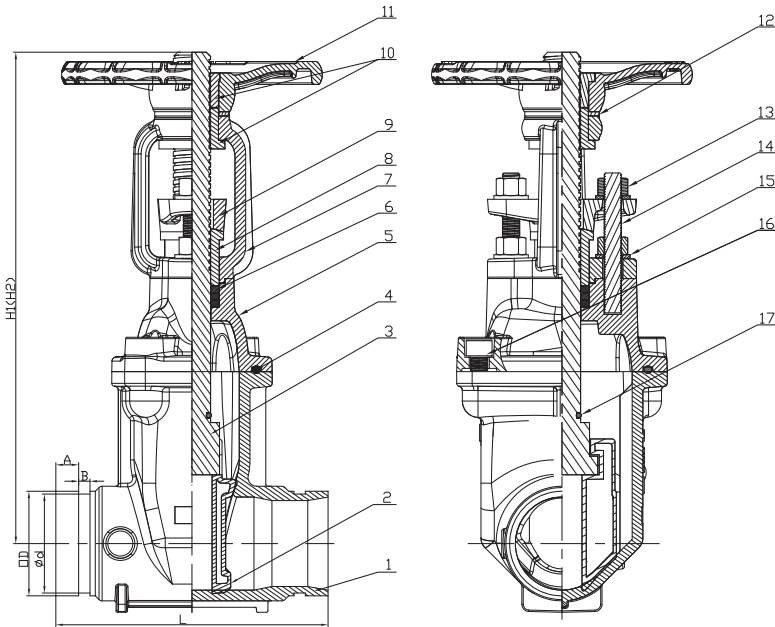

AWWA C515 Grooved Resilient OS&Y Gate Valve (JMXZ81X)



MATERIAL SPECIFICATION

PART NO.	Description	Material Specification	Options
1	Valve Body	Ductile Iron ASTM A536 , 65-45-12	
2	Resilient Wedge Disc	Ductile Iron ASTM A536,65-45-12+EPDM	
3	Stem	Stainless steel 431	Stainless steel AISI 304/316, Bronze ASTM B584
4	Bonnet Gasket	EPDM ASTM D2000	NBR ASTM D2000
5	Bonnet	Ductile Iron ASTM A536 , 65-45-12	
6	Washer	Brass ASTM B-283 C37700	
7	Yoke	Ductile Iron ASTM A536 , 65-45-12	
8	Stem Bushing	Brass ASTM B-283 C37700	
9	Gland	Ductile Iron ASTM A536 , 65-45-12	
10	Stem Nut	Brass ASTM B-283 C37700	Bronze ASTM B-584 Alloy C89833
11	Handwheel	Ductile Iron ASTM A536 , 65-45-12	Pressed Steel
12	Washer	Brass ASTM B-283 C37700	
13	Gland Nut	Stainless steel 316	Stainless steel 304
14	Stud	Stainless steel 316	Stainless steel 304
15	Flat Washer	Stainless steel 316	Stainless steel 304
16	Nut	Stainless steel 316	Stainless steel 304
17	O-Ring	EPDM ASTM D2000	NBR ASTM D2000

Note: For special material request other than standard specification, please indicate clearly on the inquiry or order list.

SIZE	Dimensions(Inch)						
	L	H1(Close)	H2(Open)	OD	d	A	B
2"	7.0	13.70	15.75	2.37	2.25	0.63	0.31
2.5"	7.5	14.69	17.32	2.87	2.72	0.63	0.31
3"	8.0	16.06	19.29	3.50	3.34	0.63	0.31
4"	9.0	18.54	22.56	4.50	4.33	0.63	0.37
5"	10.0	21.30	26.18	5.56	5.39	0.63	0.37
6"	10.5	23.66	29.72	6.63	6.46	0.63	0.37
8"	11.5	30.47	38.39	8.63	8.44	0.75	0.44
10"	13.0	40.51	50.51	10.75	10.56	0.75	0.50
12"	14.0	41.93	53.94	12.75	12.53	0.75	0.50

- Connection Ends: Groove to AWWA C606
- Working Pressure: 300PSI
200PSI and 250PSI available upon request
- Temperature Range: 0°C - 80°C
- Coating: Fusion Bonded Epoxy Coating in accordance with ANSI/AWWA C550 or painting upon request

