



## AWWA C508 Rubber Disc Swing Check Valve (JMH44J)



JMH44J

- Connection Ends: Flange to ASME B16.1 CL 125
- Working Pressure: 300PSI  
200PSI and 250PSI available upon request
- Temperature Range: 0°C- 80°C
- Coating: Fusion Bonded Epoxy Coating in accordance with ANSI/AWWA C550

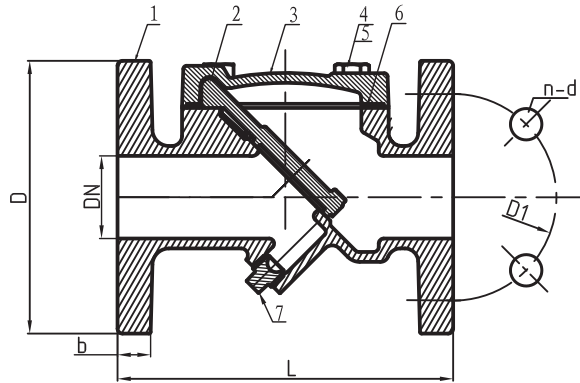

### MATERIAL SPECIFICATION

Part No.	Part	Standard Specification	Options
1	Valve Body	ASTM A536, 65-45-12	
2	Bolt	Carbon Steel Zinc Plated	AISI 304, AISI 316
3	Washer	Carbon Steel Zinc Plated	AISI 304, AISI 316
4	Disc	Carbon Steel+EPDM	Carbon Steel+NBR
5	Bonnet	ASTM A536, 65-45-12	
6	Bonnet Gasket	EPDM	
7	Plug	Malleable Iron Galvanized	Bronze ASTM B584

Note: For special material request other than standard specification, please indicate clearly on the inquiry or order list.

SIZE	Dimensions(Inch)				
	L	D	D1	b	n-Φd
2"	7.99	5.98	4.74	0.63	4-Φ0.75
2.5"	8.5	7.01	5.49	0.69	4-Φ0.75
3"	9.49	7.52	6	0.75	4-Φ0.75
4"	11.5	9.02	7.5	0.95	8-Φ0.75
5"	12.99	10	8.5	0.95	8-Φ0.88
6"	14.02	10.98	9.51	1	8-Φ0.88
8"	19.49	13.5	11.75	1.12	8-Φ0.88
10"	24.49	15.98	14.25	1.2	12-Φ1
12"	27.48	19.02	17	1.26	12-Φ1

