

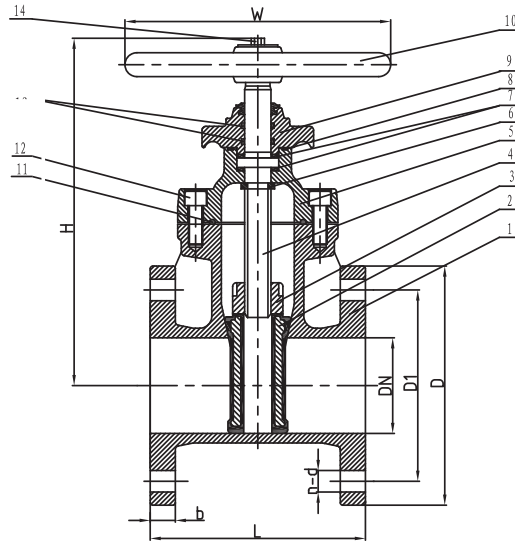

AWWA C515 Flanged Resilient NRS Gate Valve (JQZ45XC)



MATERIAL SPECIFICATION

Part NO.	PART	Standard Specification	Options
1	BODY	ASTM A536,65-45-12	
2	WEDGE	ASTM A536,65-45-12+EPDM	ASTM A536,65-45-12+NBR
3	WEDGE NUT	Brass	Bronze
4	STEM	AISI420	AISI304, AISI316, AISI 431, AISI-bronze
5	COVER	ASTM A536,65-45-12	
6	O RING	NBR	EPDM
7	O RINGS	Plastic	Brass
8	GLAND	ASTM A536,65-45-12	
9	O RING	NBR	EPDM
10	HANDWHEEL	ASTM A536,65-45-12	
11	SEAL RING	NBR	EPDM
12	BOLT	Carbon Steel Zine Plated	ANSI304, SNSI316
13	O RINGS	NBR	EPDM
14	BOLT	Carbon Steel Zine Plated	ANSI304, SNSI316

Note: For special material request other than standard specification, please indicate clearly on the inquiry or order list.

- Connection Ends: Flange to ASME B16.1 CL 125
- Working Pressure: 250PSI
- Temperature Range: 0°C- 80°C
- Coating: Fusion Bonded Epoxy Coating in accordance with ANSI/AWWA C550

SIZE	Dimensions(Inch)						
	L	H	M	D	W	N-Φd	b1
1.5"	6.50	10.24	3.88	5.00	6.30	4-0.63	0.59
2"	7.01	10.63	4.74	5.98	7.09	4-0.75	0.63
2.5"	7.48	11.14	5.49	7.01	7.09	4-0.75	0.71
3"	7.99	12.24	6.00	7.52	7.87	4-0.75	0.75
4"	9.02	13.86	7.50	9.02	9.84	8-0.75	0.94
5"	10.00	17.13	8.50	10.00	11.02	8-0.87	0.94
6"	10.51	19.09	9.51	10.98	12.60	8-0.87	1.00
8"	11.50	20.47	11.75	13.50	13.78	8-0.87	1.13
10"	12.99	24.88	14.25	15.98	15.75	12-0.98	1.19
12"	14.02	29.33	17.01	19.02	17.72	12-0.98	1.25
14"	15.00	32.87	18.74	20.98	19.69	12-1.14	1.38
16"	15.98	37.52	21.24	23.50	21.65	16-1.14	1.44
18"	17.01	41.34	22.76	25.00	23.62	16-1.26	1.57
20"	17.99	45.67	25.00	27.52	29.53	20-1.26	1.69
24"	20.00	56.89	29.51	32.01	29.53	20-1.38	1.85