

AWWA C504 Flanged xMechanical Joint Butterfly Valve(KBFV150-FM)

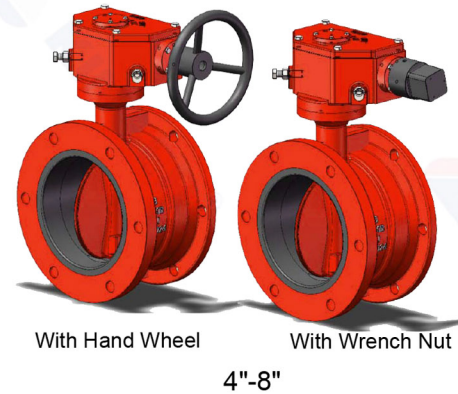
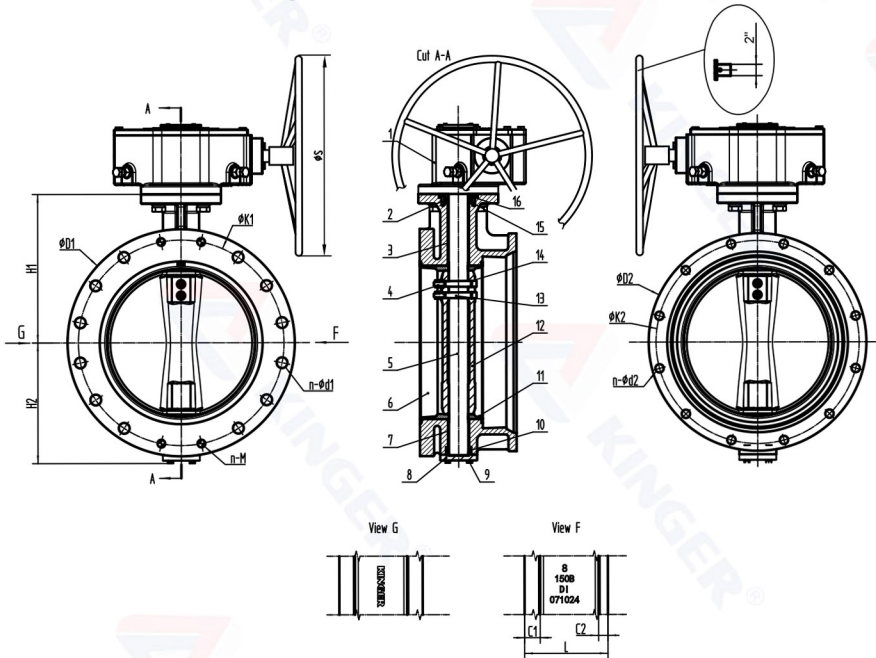

MATERIAL SPECIFICATION

Part No.	Description	Material Specification	Options
1	Gear Box		
2	Sunk screw	Stainless Steel 316	Stainless Steel 304
3	Top Bearing	Fiberglass resin back+Teflon lined	
4	Hex Nut	Stainless Steel 316	Stainless Steel 304
5	Stem	Stainless Steel 316	Stainless Steel 304
6	Body	Ductile Iron ASTM A536 65-45-12	
7	Bottom Bearing	Fiberglass resin back+Teflon lined	
8	Bottom Cover	Carbon Steel 45#	
9	Hex Bolt	Stainless Steel 316	Stainless Steel 304
10	4"-8" O-Ring 10"-24" V-Ring	EPDM ASTM D2000	NBR ASTM D2000
11	Body Seat	EPDM ASTM D2000	NBR ASTM D2000
12	Disc	DI ASTM A536+Stainless Steel 316	
13	Pin	Stainless Steel 630	
14	O-Ring	EPDM ASTM D2000	NBR ASTM D2000
15	V-Ring	EPDM ASTM D2000	NBR ASTM D2000
16	Gland	Stainless Steel 316	Stainless Steel 304

Note:For special material request other than standard specification,please indicate clearly on the inquiry or order list.
Both the hand wheel and the wrench are applicable.

- Design Standard: AWWA C504
- Flanged Standard: ASME B16.1 CLASS 125
- MJ Joint Standard: ANSI/AWWA C153/A21.53
- Working Pressure: 150 PSI
- Temperature Range:32 °F-176 °F
- Coating:Fusion Bonded Epoxy Coating in accordance with ANSI/AWWA C550

Item No.	Dimensions(Inch)														ØS
	Size	L	H1	H2	Flange					Mechanical					
					ØD1	ØK1	n-Ød1	n-M	C1	ØD2	ØK2	n-Ød2	C2		
KBFV150-FM04	4"	6.56	6.30	4.50	9.00	7.50	8 x3/4"	/	0.94	9.06	7.50	4x7/8"	0.60	8	
KBFV150-FM06	6"	6.75	8.00	5.50	11.00	9.50	8 x7/8"	/	1.00	11.06	9.50	6x7/8"	0.63	8	
KBFV150-FM08	8"	7.30	8.70	6.90	13.50	11.75	8 x7/8"	/	1.12	13.31	11.75	6 x7/8"	0.66	8	
KBFV150-FM10	10"	9.00	10.40	8.00	16.00	14.25	12 x1"	/	1.19	15.62	14.00	8 x7/8"	0.70	8	
KBFV150-FM12	12"	9.25	11.60	9.50	19.00	17.00	12 x1"	/	1.25	17.88	16.25	8x7/8"	0.73	8	
KBFV150-FM14	14"	9.75	13.40	12.00	21.00	18.75	12 x1 1/8"	/	1.38	20.25	18.75	10 x7/8"	0.79	20	
KBFV150-FM16	16"	10.00	14.60	13.00	23.50	21.25	12 x1 1/8"	4x1-8UNC	1.44	22.50	21.00	12 x7/8"	0.85	20	
KBFV150-FM18	18"	10.13	16.00	14.20	25.00	22.75	12 x1 1/4"	4x1 1/8-7UNC	1.56	24.83	23.25	12 x7/8"	1.00	20	
KBFV150-FM20	20"	10.13	16.50	15.40	27.50	25.00	16 x1 1/4"	4x1 1/8-7UNC	1.69	27.08	25.50	14 x7/8"	1.02	20	
KBFV150-FM24	24"	10.63	18.50	16.50	32.00	29.50	16 x1 3/8"	4x1 1/4-7UNC	1.88	31.58	30.00	16 x7/8"	1.02	20	