

AWWA C504 Mechanical Joint Valve(KBFV150-MJ)

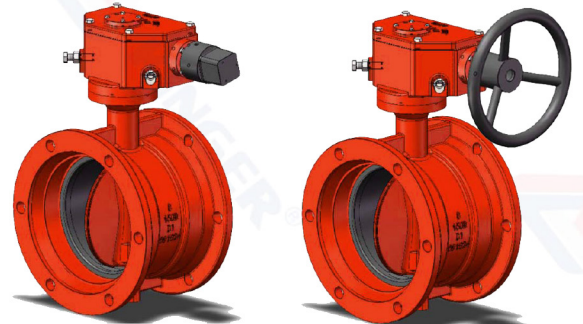

With Wrench Nut 4"-8" With Hand Wheel

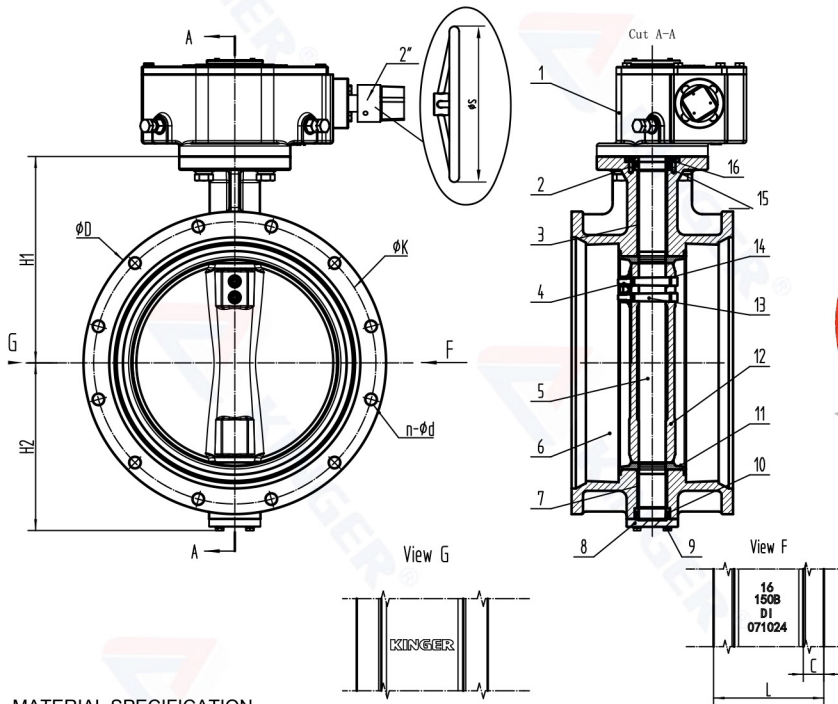
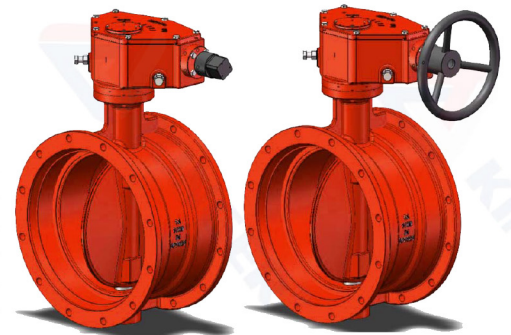

With Wrench Nut With Hand Wheel
10"-24"

MATERIAL SPECIFICATION

Part No.	Description	Material Specification	Options
1	Gear Box		
2	Sunk screw	Stainless Steel 316	Stainless Steel 304
3	Top Bearing	Fiberglass resin back+Teflon lined	
4	Hex Nut	Stainless Steel 316	Stainless Steel 304
5	Stem	Stainless Steel 316	Stainless Steel 304
6	Body	Ductile Iron ASTM A536 65-45-12	
7	Bottom Bearing	Fiberglass resin back+Teflon lined	
8	Bottom Cover	Carbon Steel 45#	
9	Hex Bolt	Stainless Steel 316	Stainless Steel 304
10	4"-8" O-Ring 10"-24" V-Ring	EPDM ASTM D2000	NBR ASTM D2000
11	Body Seat	EPDM ASTM D2000	NBR ASTM D2000
12	Disc	DI ASTM A536+Stainless Steel 316	
13	Pin	Stainless Steel 630	
14	O-Ring	EPDM ASTM D2000	NBR ASTM D2000
15	V-Ring	EPDM ASTM D2000	NBR ASTM D2000
16	Gland	Stainless Steel 316	Stainless Steel 304

Note:For special material request other than standard specification,please indicate clearly on the inquiry or order list.
Both the hand wheel and the wrench are applicable.

Item No.	Dimensions(Inch)								φS
	Size	L	H1	H2	φD	φK	n-φd	C	
KBFV150-MJ04	4"	8.13	6.30	4.50	9.06	7.50	4x7/8"	0.60	8
KBFV150-MJ06	6"	8.00	8.00	5.50	11.06	9.50	6x7/8"	0.63	8
KBFV150-MJ08	8"	8.70	8.70	6.90	13.31	11.75	6 x7/8"	0.66	8
KBFV150-MJ10	10"	10.00	10.24	8.00	15.62	14.00	8 x7/8"	0.70	8
KBFV150-MJ12	12"	10.50	11.50	9.50	17.88	16.25	8x7/8"	0.73	8
KBFV150-MJ14	14"	11.50	13.40	12.00	20.25	18.75	10 x7/8"	0.79	20
KBFV150-MJ16	16"	12.00	15.35	13.00	22.50	21.00	12 x7/8"	0.85	20
KBFV150-MJ18	18"	12.25	15.16	14.20	24.83	23.25	12 x7/8"	1.00	20
KBFV150-MJ20	20"	12.50	17.13	15.40	27.08	25.50	14 x7/8"	1.02	20
KBFV150-MJ24	24"	13.25	19.69	18.90	31.58	30.00	16 x7/8"	1.02	20