

AWWA C508 Flanged Metal-Seated Swing Check Valve 250PSI(JHH44XW)

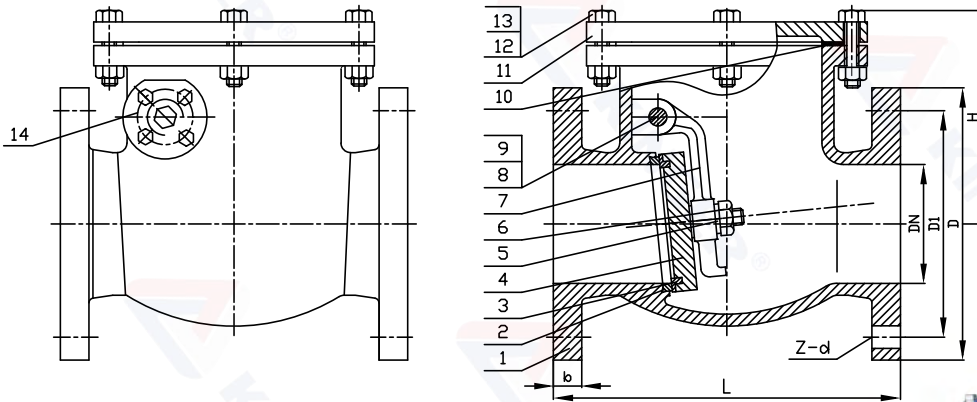

MATERIAL SPECIFICATION

Part No.	Description	Material Specification
1	Body	Ductile Iron ASTM A536
2	Body Seat Ring	Brass ASTM B62
3	Disk Seat Ring	Brass ASTM B62
4	Disc	Ductile Iron ASTM A536
5	Washer	Stainless Steel SS316
6	Nut	Stainless Steel SS316
7	Arm	Ductile Iron ASTM A536
8	Hing Pin	Stainless Steel SS420
9	O-Ring	NBR ASTM D2000
10	Gasket	NBR ASTM D2000
11	Bonnet	Ductile Iron ASTM A536
12	Bolt	Stainless Steel SS316
13	Nut	Stainless Steel SS316
		Size:1.5-6" N/A Size:8-36" A
14	Gland	Brass ASTM B16
		Ductile Iron ASTM A536



- Design Basis: AWWA C508
- Connection Ends: Flange to ASME B16.1 CL 125/ASME B16.42 CL150
- Working Pressure: 250PSI available upon request
- Temperature Range: 14 -176
- Coating: Fusion Bonded Epoxy Coating in accordance with ANSI/AWWA C550

Note:For special material request other than standard specification,please indicate clearly on the inquiry or order list.

Item No.	Dimensions(Inch)							
	SIZE	D	D1	b	z	d	L	H
JHH44XW015	1.5"	5.00	3.88	0.56	4	0.625	6.50	4.72
JHH44XW02	2"	6.00	4.75	0.62	4	0.750	8.00	5.39
JHH44XW025	2.5"	7.00	5.50	0.69	4	0.750	8.50	5.63
JHH44XW03	3"	7.50	6.00	0.75	4	0.750	9.50	6.06
JHH44XW04	4"	9.00	7.50	0.94	8	0.750	11.50	6.73
JHH44XW05	5"	10.00	8.50	0.94	8	0.875	13.00	8.03
JHH44XW06	6"	11.00	9.50	1.00	8	0.875	14.00	8.62
JHH44XW08	8"	13.50	11.75	1.12	8	0.875	19.50	10.16
JHH44XW10	10"	16.00	14.25	1.19	12	1.000	24.50	11.42
JHH44XW12	12"	19.00	17.00	1.25	12	1.000	27.50	12.80
JHH44XW14	14"	21.00	18.75	1.38	12	1.125	31.00	14.21
JHH44XW16	16"	23.50	21.25	1.44	16	1.125	36.00	15.28
JHH44XW18	18"	25.00	22.75	1.56	16	1.250	40.00	17.72
JHH44XW20	20"	27.50	25.00	1.69	20	1.250	40.00	20.39
JHH44XW24	24"	32.00	29.50	1.88	20	1.375	48.00	24.41
JHH44XW30	30"	38.75	36.00	2.12	28	1.375	56.00	30.04
JHH44XW36	36"	46.00	42.75	2.38	32	1.625	77.00	37.80